

FEATURES

- ❖ High dynamic range
- ❖ Low insertion loss
- ❖ Broad operating bandwidth
- ❖ Pin diode or MMIC based circuitry
- ❖ Current or voltage controlled

APPLICATIONS

- ❖ Automatic level control
- ❖ Amplitude modulation
- ❖ Instrumentation

DESCRIPTION

CAE series are discrete or MMIC PIN diode based current or voltage controlled electrical attenuators that operate at the frequency range from DC to 110 GHz. These attenuators are especially designed for low insertion loss and high attenuation applications. While PIN diode based attenuators are designed for waveguide bandwidth operation from 18 to 110 GHz, the MMIC based attenuators are designed for broadband operation from DC up to 50 GHz. The maximum attenuation value up to 100 dB is available.

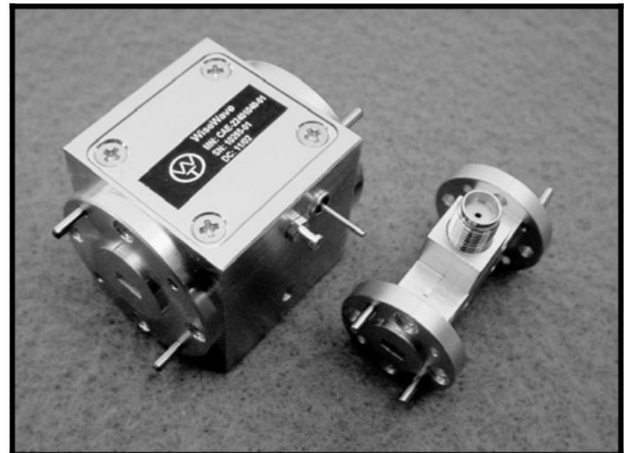

CAE Series

WAVEGUIDE INTERFACE ATTENUATOR SPECIFICATIONS

Frequency Range (GHz)	Maximum Available Bandwidth (GHz)	Insertion Loss (dB, Typ)*	Attenuation (dB, Min)	VSWR (Typ)	Tuning Speed (nS)	Outline* Drawing
18 to 26.5	Full	1.2	20	2:1	10 to 250	WT-H-3
26.5 to 40	Full	1.5	20	2:1	10 to 250	WT-H-3
33 to 50	10	1.8	20	2:1	10 to 250	WT-H-3, WT-H-4
40 to 60	10	2.0	20	2:1	10 to 250	WT-H-3, WT-H-4
50 to 75	10	2.2	20	2:1	10 to 250	WT-H-3
60 to 90	10	2.3	20	2:1	10 to 250	WT-H-3
75 to 110	10	2.5	20	2:1	10 to 250	WT-H-3
Temperature Range	0 to +50°C					

* Insertion Loss & Isolation are for waveguide version.

** Consult factory for the attenuators with the outline and specifications other than listed above.

HOW TO ORDER

The attenuators with the performance other than listed above are available per customer's request. You may submit your specifications along with the model number per following instruction.

Specify Model Number:

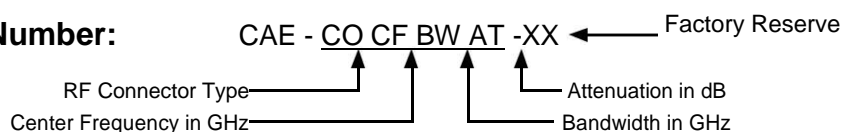

Example: To order an electrical attenuator with center frequency of 35 GHz, +/- 5 GHz bandwidth, 35 dB minimum attenuation and WR-28 waveguide interface, specify CAE-28351035-XX.

Control Device Outline Drawings #1

WT-H-1

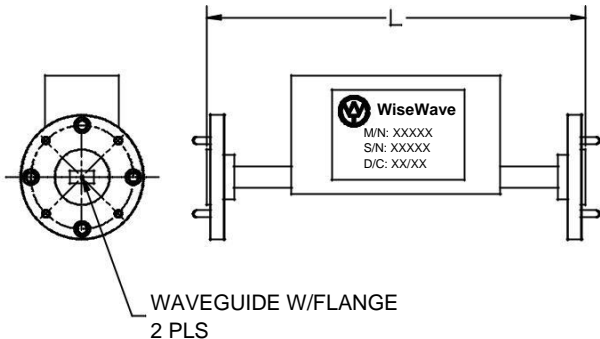

BAND	W, E & V	U, Q & Ka	K
L	2.50	3.50	4.00

Dimensions are in inches

WT-H-2

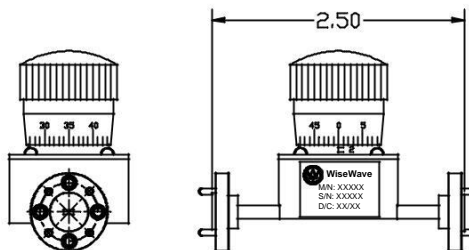

W, E, V & U BAND

Dimensions are in inches

WT-H-3

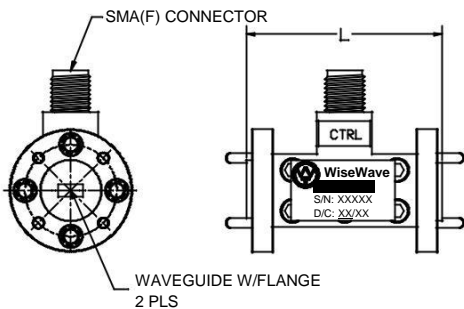

BAND	W, E & V	U & Q	Ka & K
L	1.20	1.50	2.00

Dimensions are in inches

WT-H-4

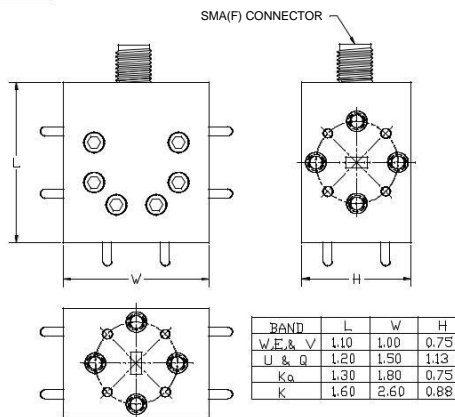

BAND	L	W	H
W, E & V	1.10	1.00	0.75
U & Q	1.20	1.50	1.13
Ka	1.30	1.80	0.75
K	1.60	2.60	0.88

Dimensions are in inches

WT-H-5

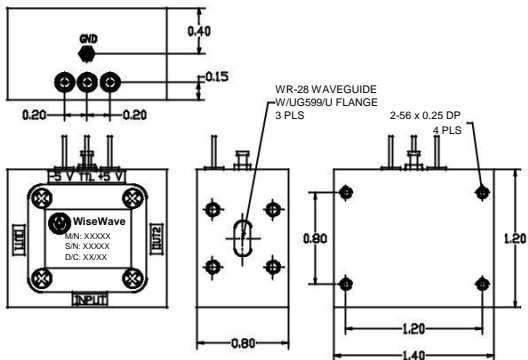

Dimensions are in inches

WT-H-6

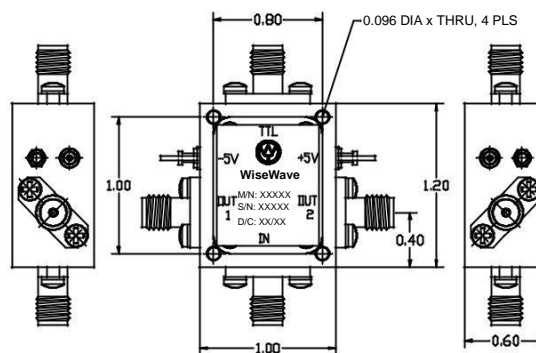

Dimensions are in inches

The flange pattern shown is for illustration purpose. Refer to Technical Reference Section for flange pattern details. The outline drawings shown are standard versions. Contact factory for your specific package requirements.