

PIN Diode Switches

Bulletin No. CPS, CPD and CPM

FEATURES

- ❖ Low insertion loss
- ❖ High isolation
- ❖ High speed available
- ❖ TTL control available
- ❖ Single, double and multi-throw

APPLICATIONS

- ❖ Pulse modulation
- ❖ Radar duplexing
- ❖ Receiver protection
- ❖ Antenna beam switching

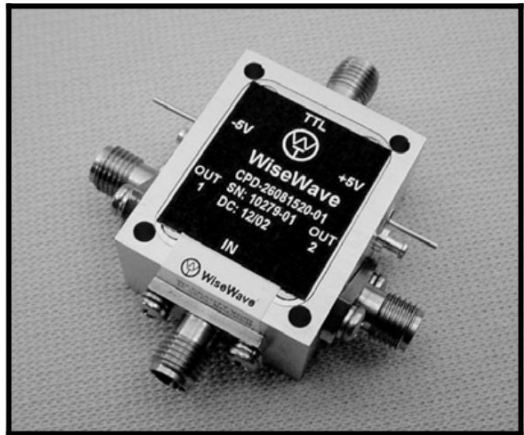

CPS, CPD & CPM Series

DESCRIPTION

CPS, CPD and CPM series are discrete or MMIC based PIN diode switches that operate at the frequency range from 18 to 110 GHz. These switches are especially designed for low insertion loss and high isolation applications. While these switches are designed for broadband operation, lower insertion loss and higher isolation can be achieved by optimizing design for specific narrower frequency range. These PIN diode switches are reflective type and can be tailored to absorptive type by integrating input and output isolators. Furthermore, the internal TTL driver is offered as an option for ease TTL control.

SPECIFICATIONS

Frequency Range (GHz)	Maximum Available Bandwidth (GHz)	Insertion Loss (dB, Typ)*			Isolation (dB, Min)*	VSWR (Typ)	Switch Speed (nS, Min)
		SPST	SPDT	SPMT			
18 - 26.5	Full	1.2	1.8	C F o a c t u o r y	20	2:1	250
26.5 - 40	Full	1.5	2.0		20	2:1	250
33 to 50	10	1.8	2.2		20	2:1	250
40 to 60	10	2.0	2.4		20	2:1	250
50 to 75	10	2.2	2.6		20	2:1	250
60 to 90	10	2.3	2.8		20	2:1	250
75 to 110	10	2.5	3.0		20	2:1	250
Temperature Range	0 to +50°C						

* Insertion Loss & Isolation are for waveguide version.

** Consult factory for the switches with the outlines and specifications other than listed above.

HOW TO ORDER

The switches with the performance other than listed above are available per customer's request. You may submit your specifications along with the model number per following instruction.

Specify Model Number:

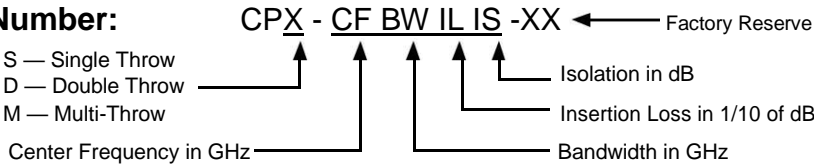

Example: To order a SPDT switch with center frequency of 60 GHz, 4 GHz bandwidth, 2.2 dB insertion loss and 20 dB isolation, specify CPS-60042220-XX.

Control Device Outline Drawings #1

WT-H-1

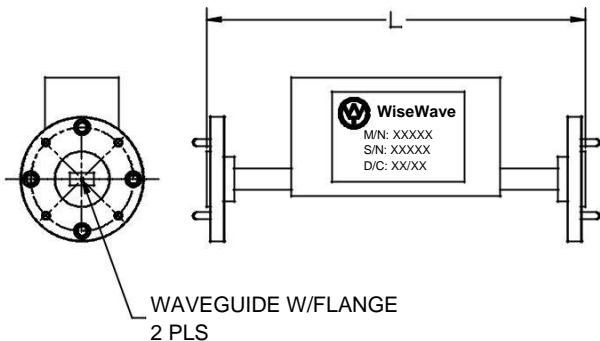

BAND	W, E & V	U, Q & Ka	K
L	2.50	3.50	4.00

Dimensions are in inches

WT-H-2

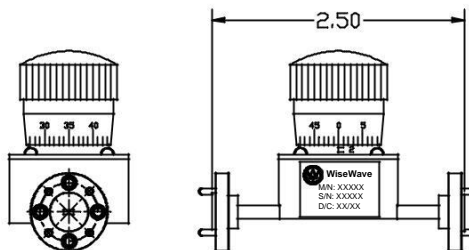

W, E, V & U BAND

Dimensions are in inches

WT-H-3

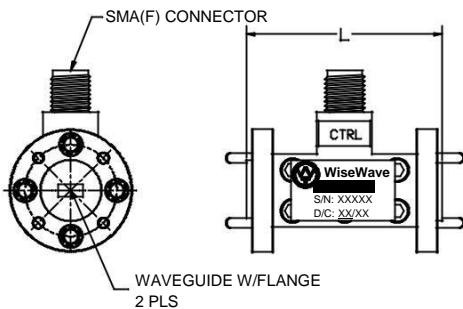

BAND	W, E & V	U & Q	Ka & K
L	1.20	1.50	2.00

Dimensions are in inches

WT-H-4

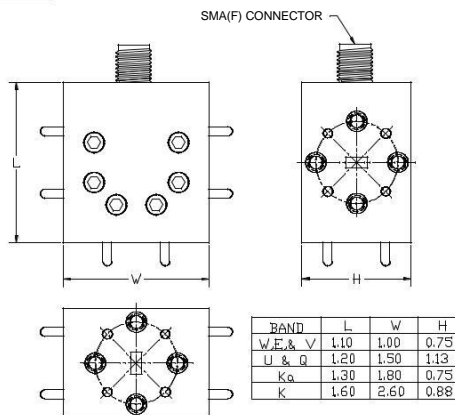

BAND	L	W	H
W, E & V	1.10	1.00	0.75
U & Q	1.20	1.50	1.13
Ka	1.30	1.80	0.75
K	1.60	2.60	0.88

Dimensions are in inches

WT-H-5

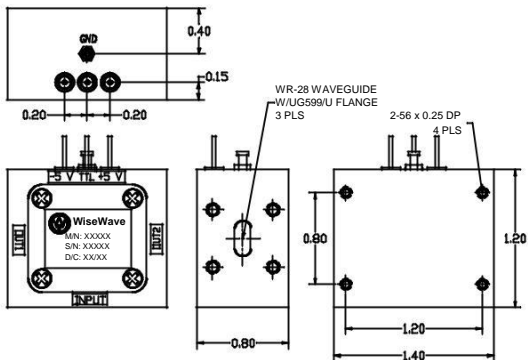

Dimensions are in inches

WT-H-6

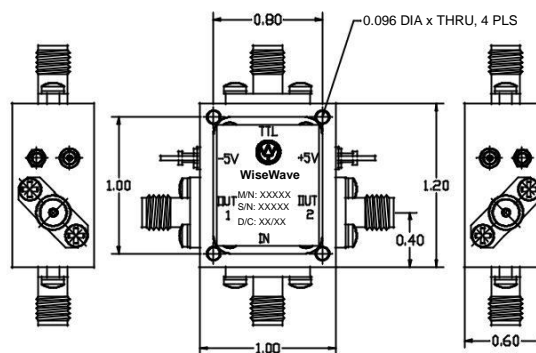

Dimensions are in inches

The flange pattern shown is for illustration purpose. Refer to Technical Reference Section for flange pattern details. The outline drawings shown are standard versions. Contact factory for your specific package requirements.