

FEATURES

- ❖ High output power
- ❖ Up to full waveguide operation
- ❖ Moderate conversion gain
- ❖ Frequency up to 96 GHz
- ❖ Single power supply

APPLICATIONS

- ❖ Frequency extenders
- ❖ Test set
- ❖ Local oscillators
- ❖ Subsystems



FMA Series

DESCRIPTION

FMA series active multipliers utilize high performance GaAs Schottky beamlead diodes or discrete PHEMT devices and/or MMIC chips for frequency multiplication and amplification. The multipliers offer moderate conversion gain with output frequency covering 18 to 96 GHz in six waveguide bands. The X2, X3 and X4 are offered as standard multiplication factors. The input power requirement for these multipliers is +10 to +20 dBm. While SMA or K female coaxial connector is equipped for input and waveguide for output interface, WR-28 waveguide input is available as an option for V band doubler and W band tripler design.

SPECIFICATIONS

Output Freq. (GHz)	Multiplying Factor	Input Freq. (GHz)	Output Power (dBm, Typ)	Bandwidth (GHz)	Output Waveguide	Input Connector
18.0-26.5	X 2	9.0-13.25	10 to 30	± 2 to Full	WR-42	SMA(F)
26.5-40.0	X 2	13.25-20.0	10 to 25	± 2 to Full	WR-28	SMA(F)
	X 4	6.625-10.0	10 to 25	± 2 to Full	WR-28	SMA(F)
33.0-42.0	X 2	16.5-21.0	10 to 23	± 2 to ± 4	WR-22	SMA(F)
	X 4	8.25-10.5	7 to 23	± 2 to ± 4	WR-22	SMA(F)
54.0-65.0	X 2	27.0-32.5	7 to 16	± 2 to ± 6	WR-15	K(F)
	X 4	13.5-16.25	7 to 16	± 2 to ± 6	WR-15	K(F)
92.0-96.0	X 2	46.0-48.0	7 to 20	± 2	WR-10	2.4mm(F)
	X 6	15.3-16.0	5 to 20	± 2	WR-10	SMA(F)
Temperature Range			0 to +50°C			

* Consult factory for other active multiplier and outline requirements.

HOW TO ORDER

Specify Model Number:

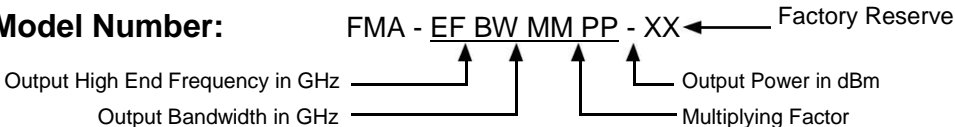

Example: To order an active doubler with output end frequency 65 GHz, bandwidth 10 GHz and power 16 dBm, specify FMA-65100216-XX.

Frequency Converter Outline Drawings #1

WT-F-1

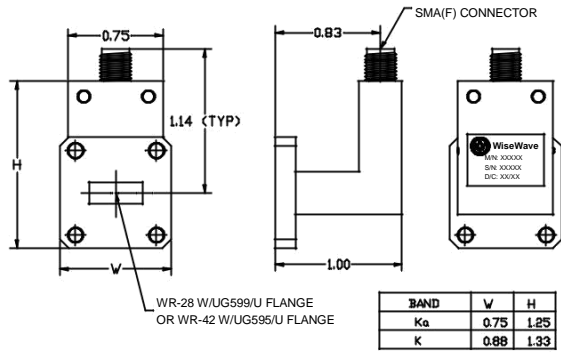

Dimensions are in inches

WT-F-2

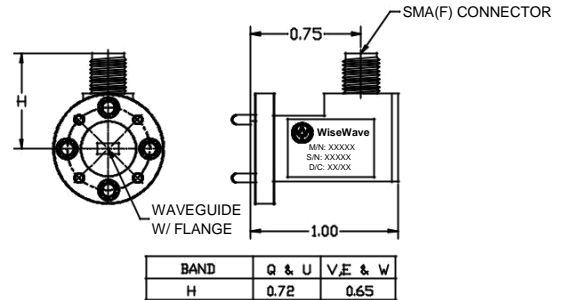

Dimensions are in inches

WT-F-3

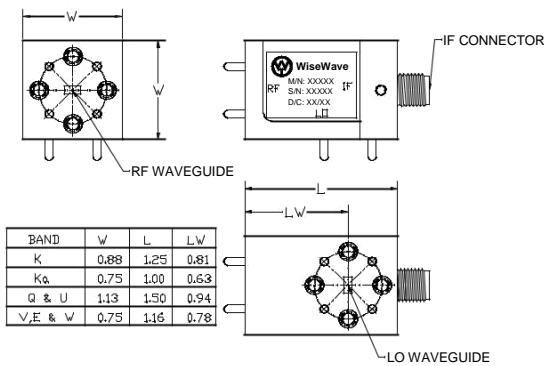

Dimensions are in inches

WT-F-4

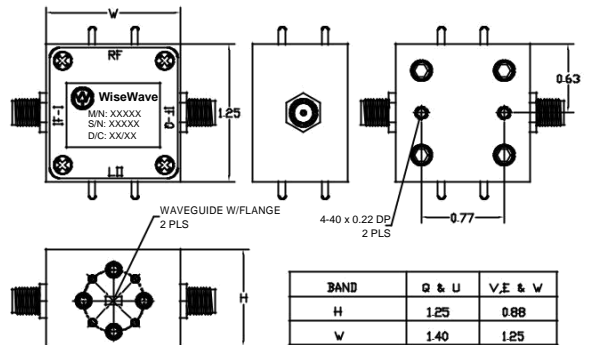

Dimensions are in inches

WT-F-5

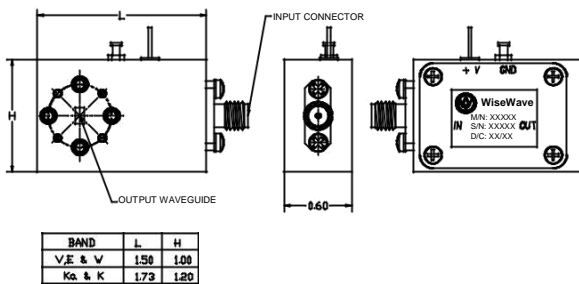

Dimensions are in inches

WT-F-6

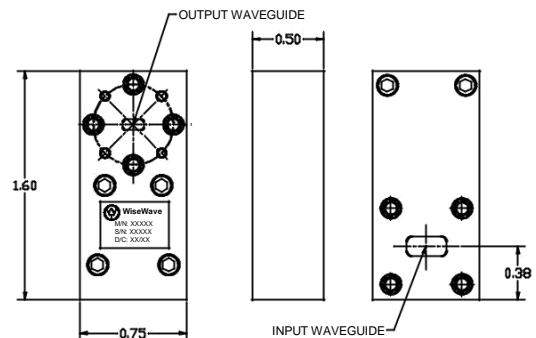

Dimensions are in inches

The flange pattern shown is for illustration purpose. Refer to Technical Reference Section for flange pattern details. The outline drawings shown are standard versions. Contact factory for your specific package requirements.

Frequency Converter Outline Drawings #2

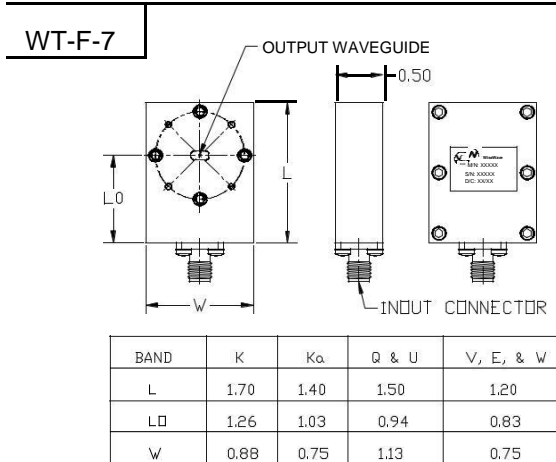

Dimensions are in inches

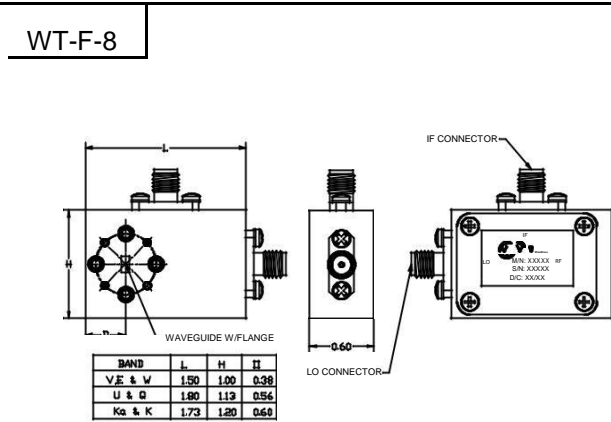

Dimensions are in inches

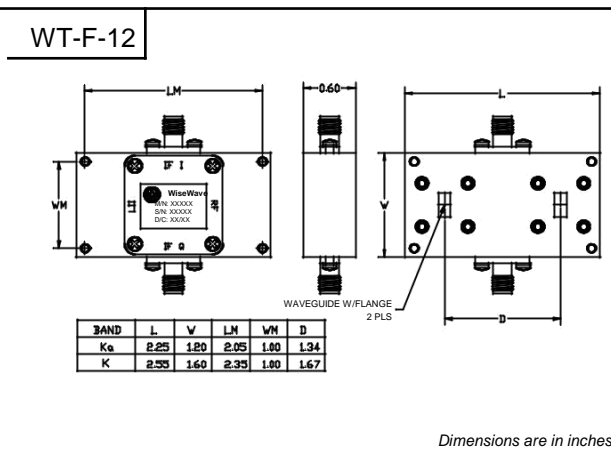
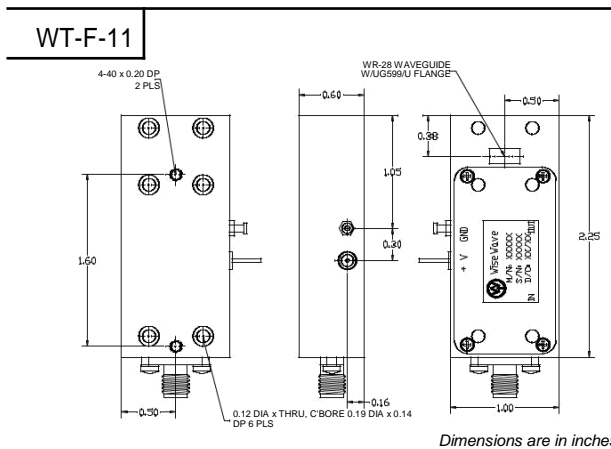
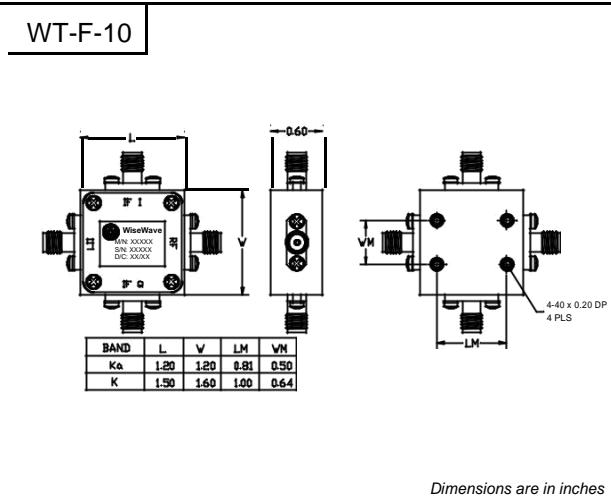
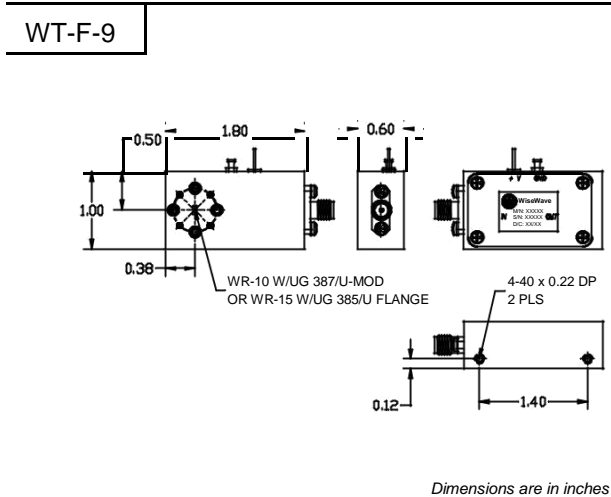

The flange pattern shown is for illustration purpose. Refer to Technical Reference Section for flange pattern details. The outline drawings shown are standard versions. Contact factory for your specific package requirements.